

#### 4. Design Issues for 10nm MOSFETs.....

*a numerical study*

---

- series resistance and low  $V_{DS}$  are key issues
- off-current is extremely sensitive to process variations
- hi-K gives only ~ 20% boost in on-current
- S/D abruptness increases device footprint and  $R_{par}$

## 5. Beyond the Si MOSFET.....

### 1) MOSFET

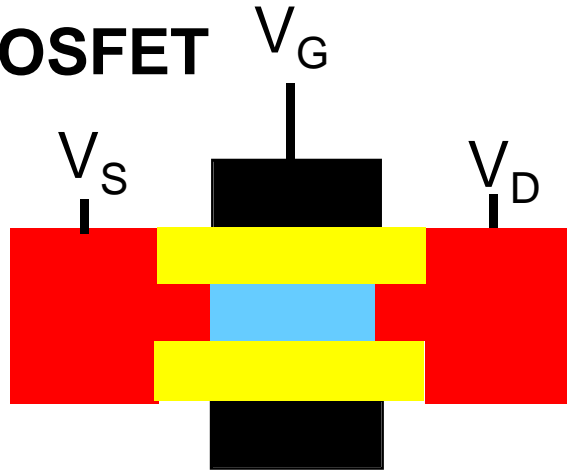

### 2) SBFET

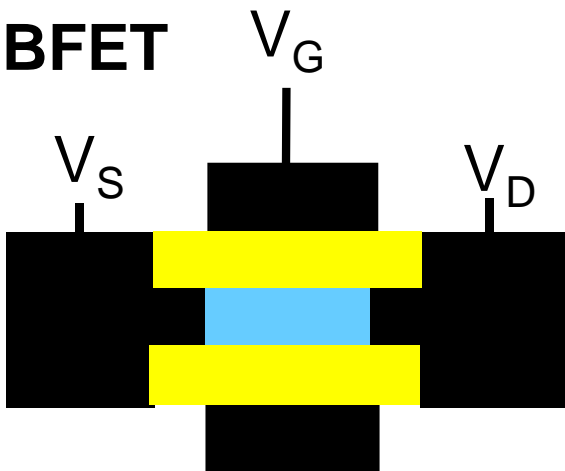

Lundstrom

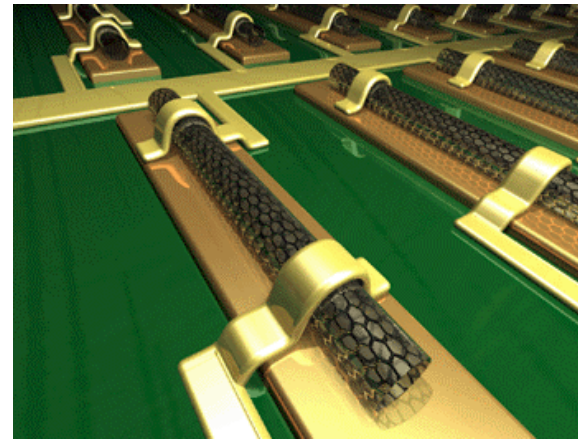

### 3) CNTFET

Bachtold, et al.,  
Science, Nov.  
2001

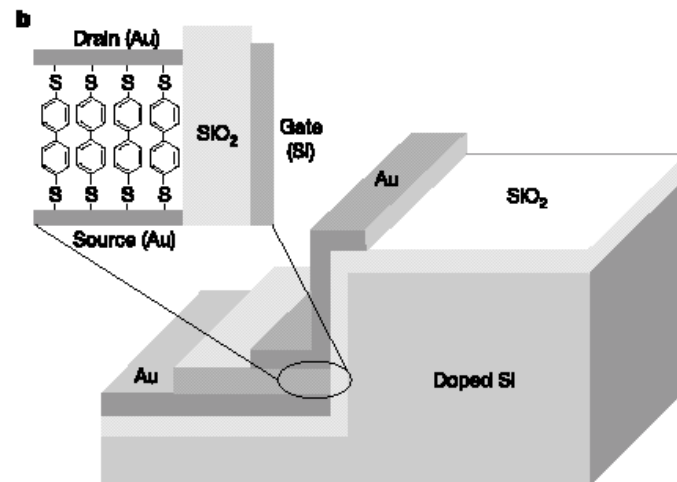

### 4) SAMFET

Schön, et al.,  
Nature, **413**,  
713, 2001

Purdue

## 5. Beyond the Si MOSFET.....

## *the Schottky barrier MOSFET*

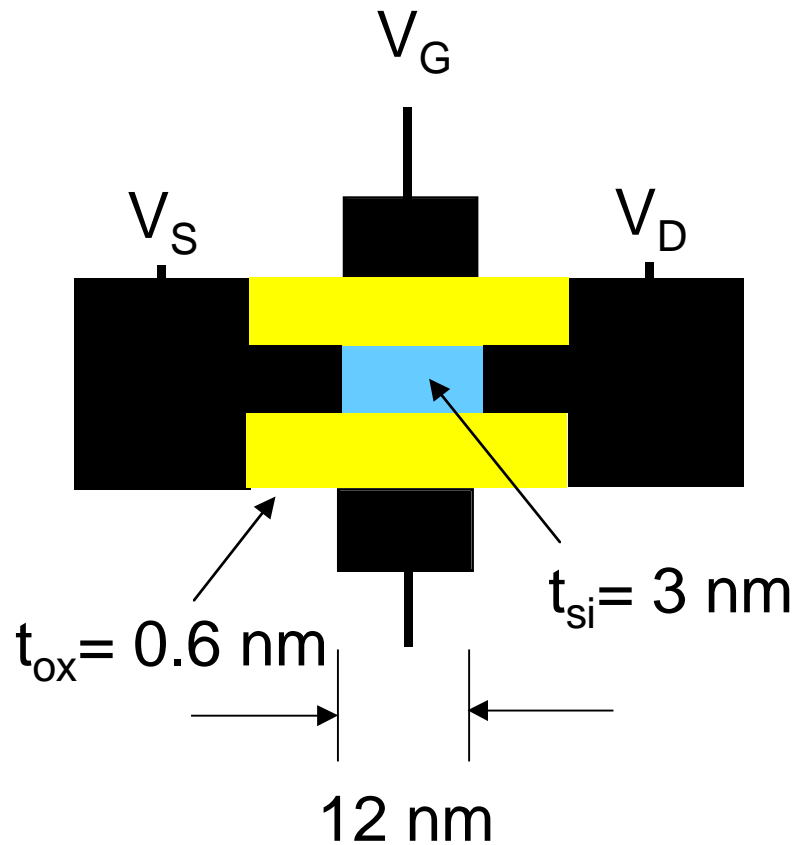

Jing Guo (Purdue)

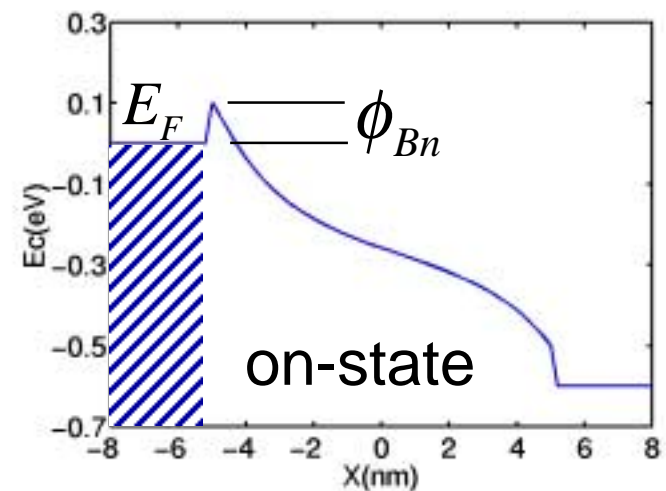
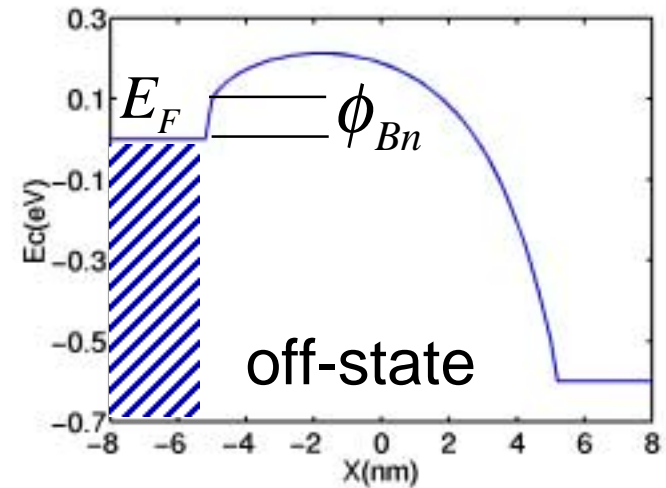

## 5. Beyond the Si MOSFET.....

*the Schottky barrier MOSFET*

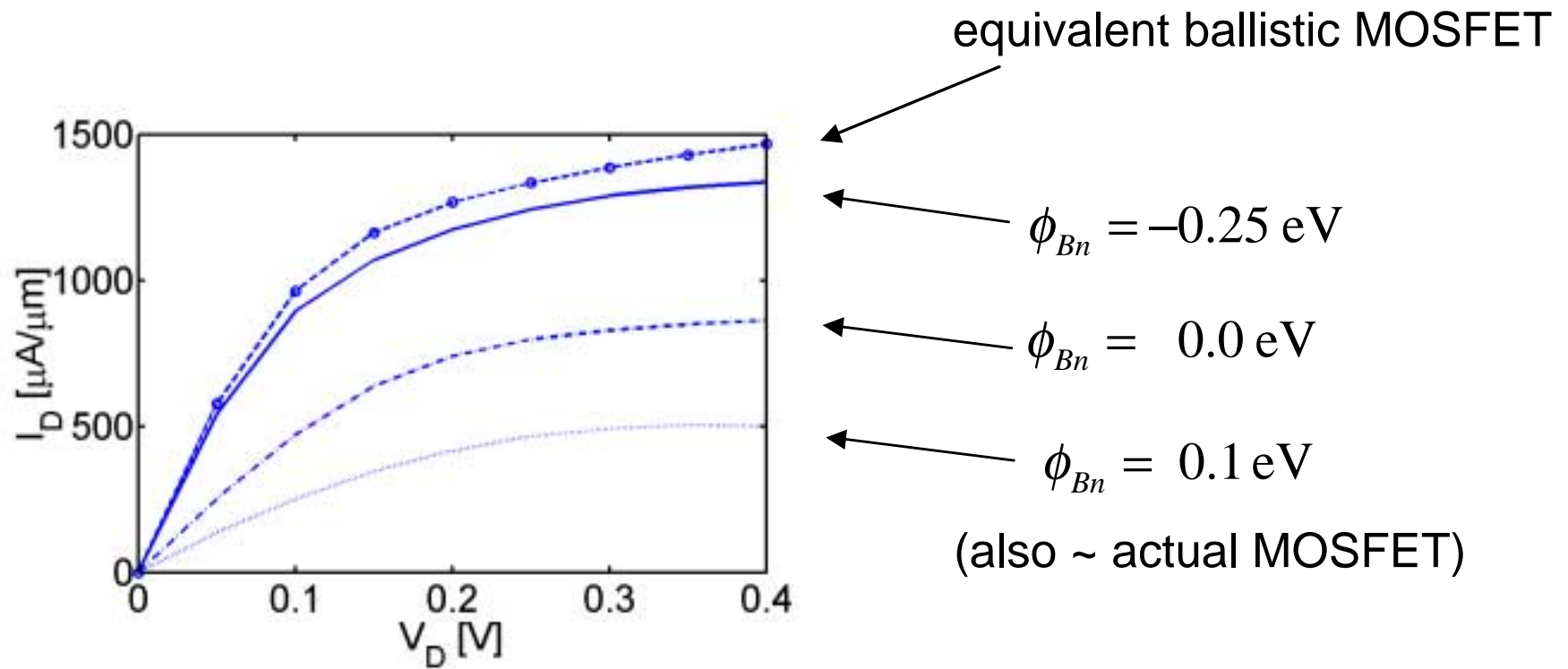

## 5. Beyond the Si MOSFET.....

*the Schottky barrier MOSFET*

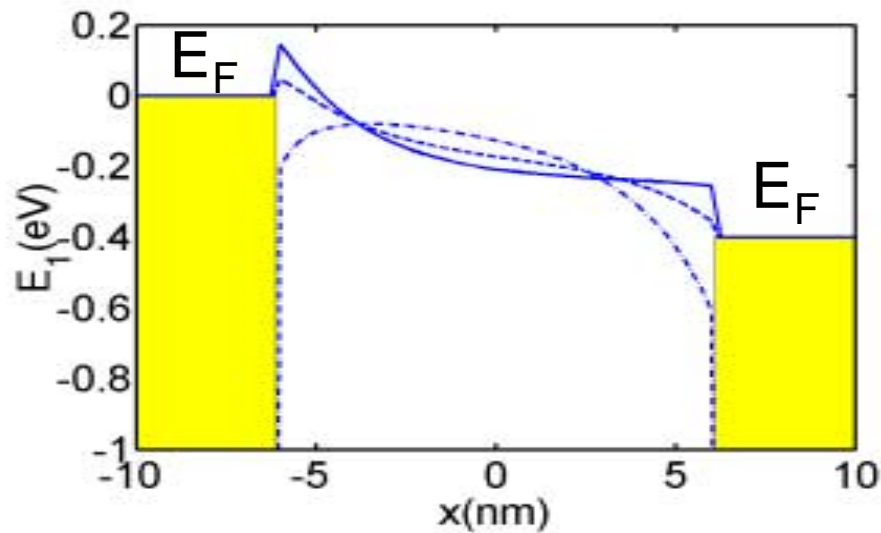

- - - - - MOSFET  
 ——— SBFET  
 ( $\phi_{Bn} = -0.25 \text{ eV}$ )

$$\phi_{Bn} = 0.1 \text{ eV}$$

$$\phi_{Bn} = 0.0 \text{ eV}$$

$$\phi_{Bn} = -0.25 \text{ eV}$$

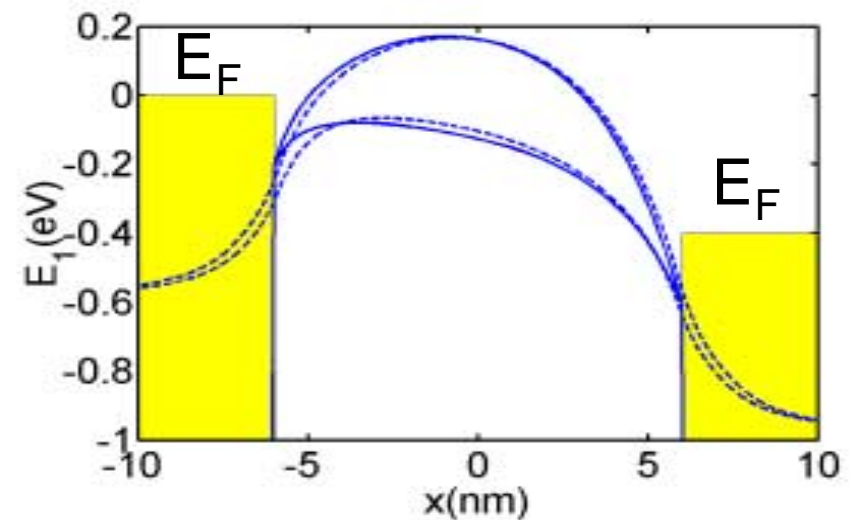

## 5. Beyond the Si MOSFET.....

## *the Schottky barrier MOSFET*

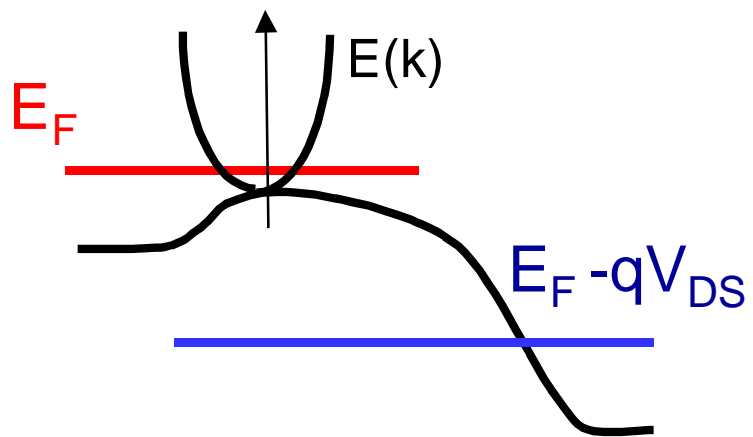

MOSFET

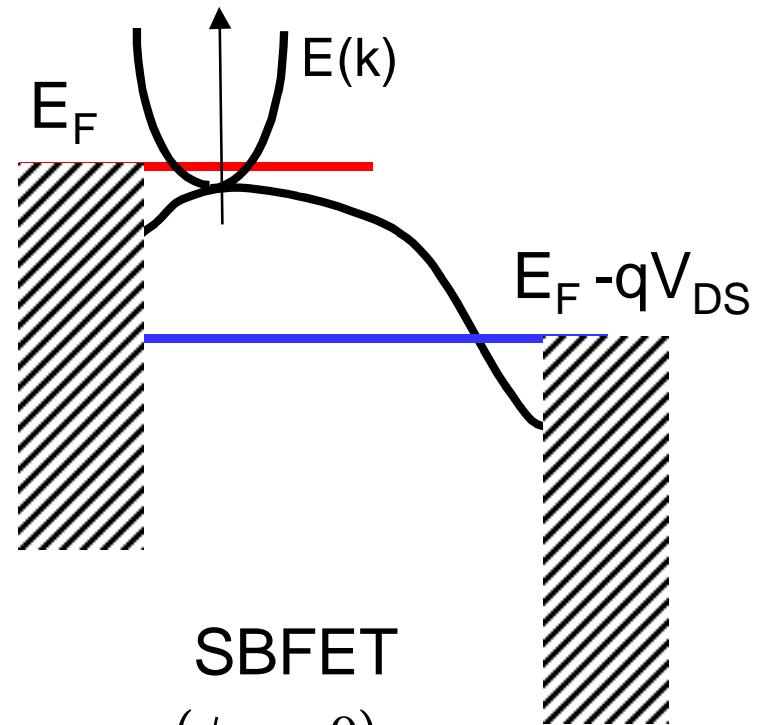

SBFET  
( $\phi_{Bn} < 0$ )

5. Beyond the Si MOSFET.....

*the CNTFET*

graphene

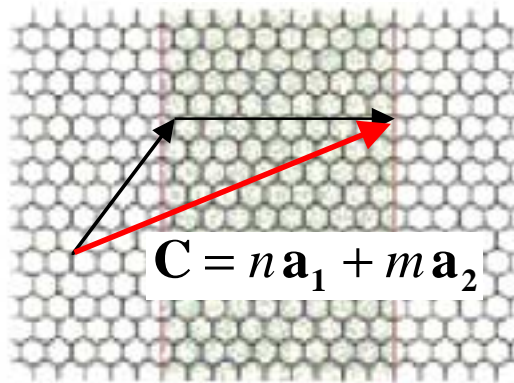

(n, m) carbon nanotube



$$\mathbf{k} \cdot \mathbf{C} = 2\pi q$$

(n-m) = multiple of 3

(n-m)  $\neq$  multiple of 3

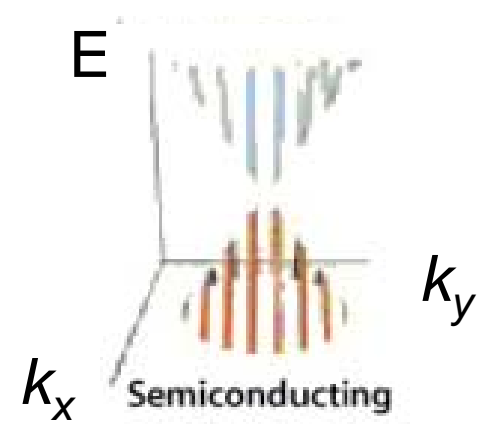
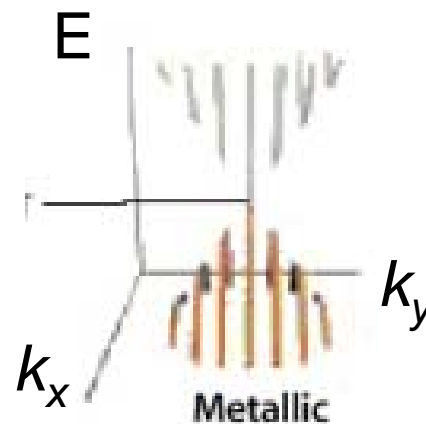
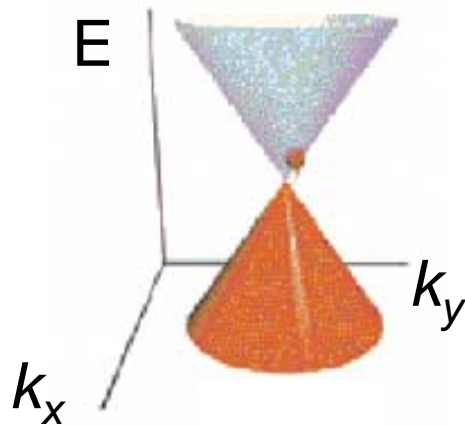

# 5. Beyond the Si MOSFET.....

# the CNTFET

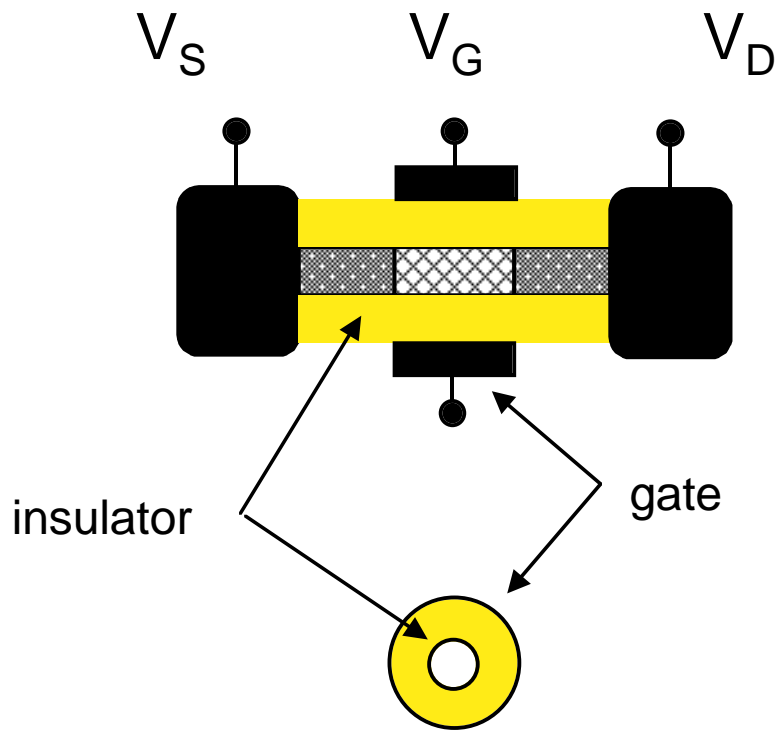

*coaxial geometry*

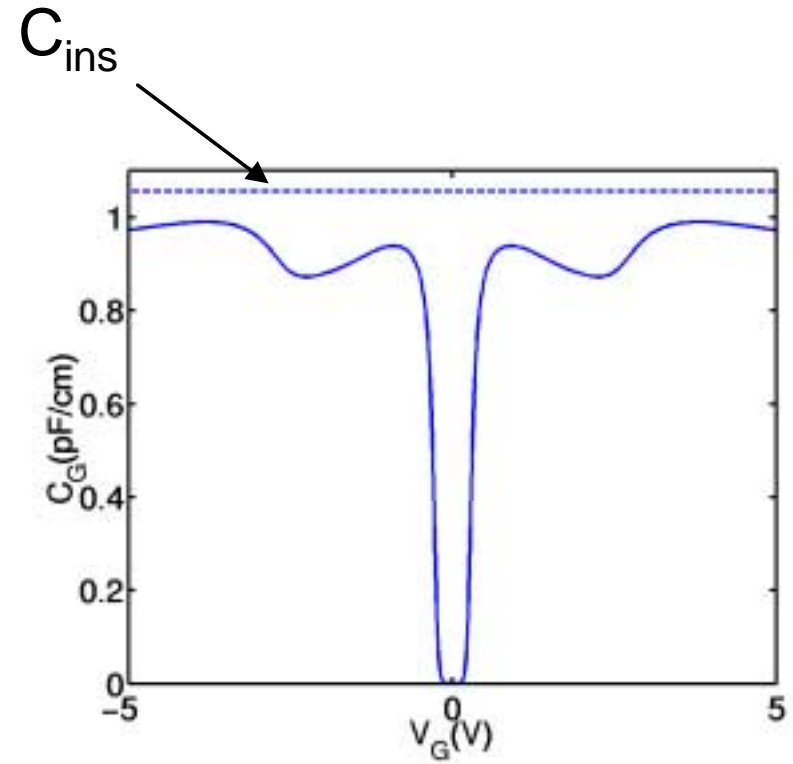

*MIS  $C_G$  vs.  $V_G$*

## 5. Beyond the Si MOSFET.....

*the CNTFET*

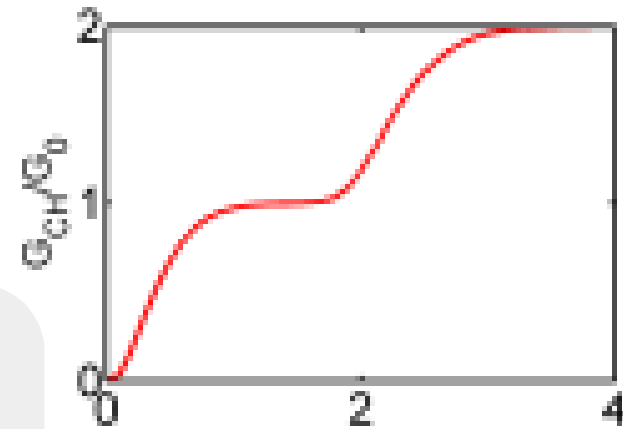
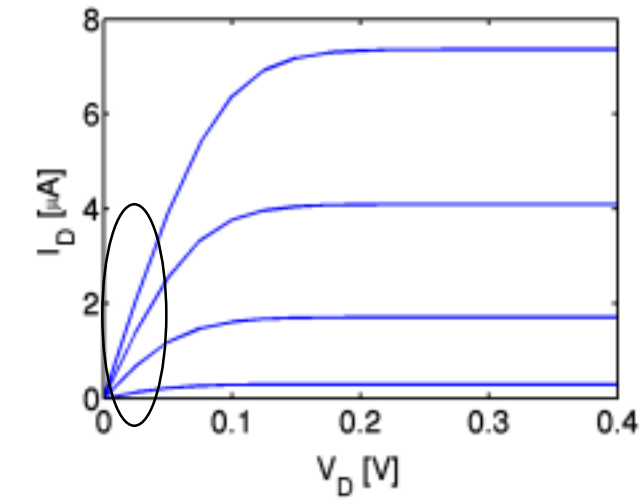

$D = 1 \text{ nm}$   
 $t_{\text{ins}} = 1 \text{ nm}$   
 $K_{\text{ins}} = 4$   
 $V_{DD} = 0.4$

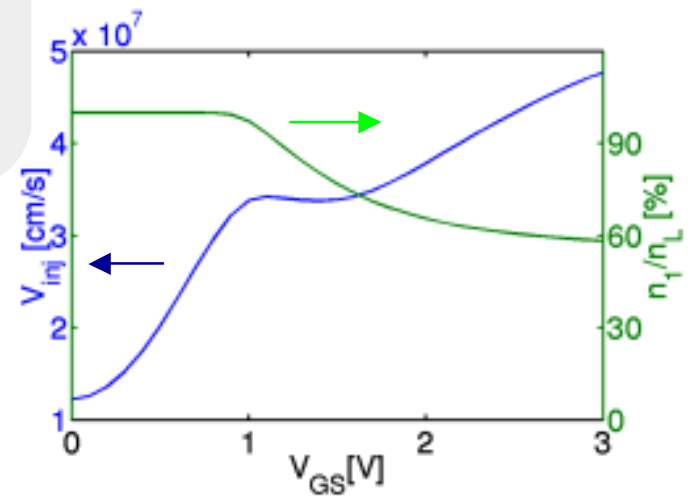
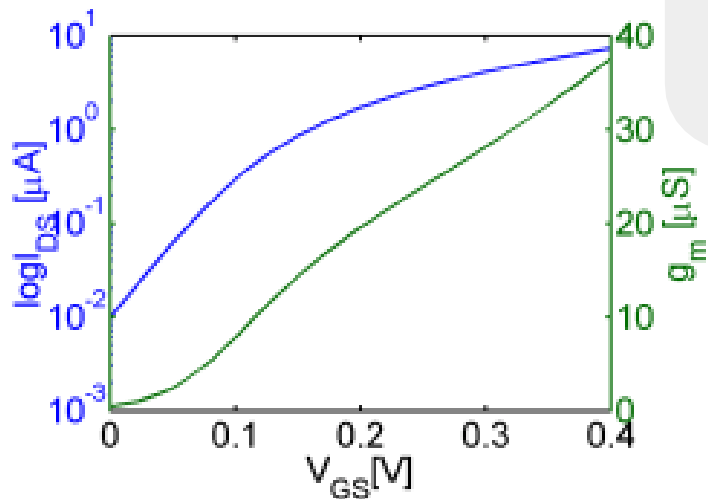

## 5. Beyond the Si MOSFET.....

*the CNTFET*

### planar geometry CNTFET

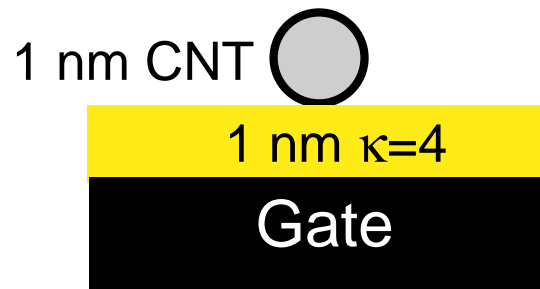
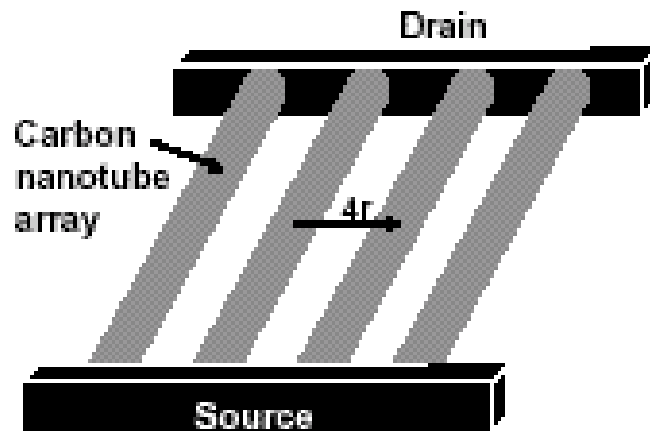

Lundstrom

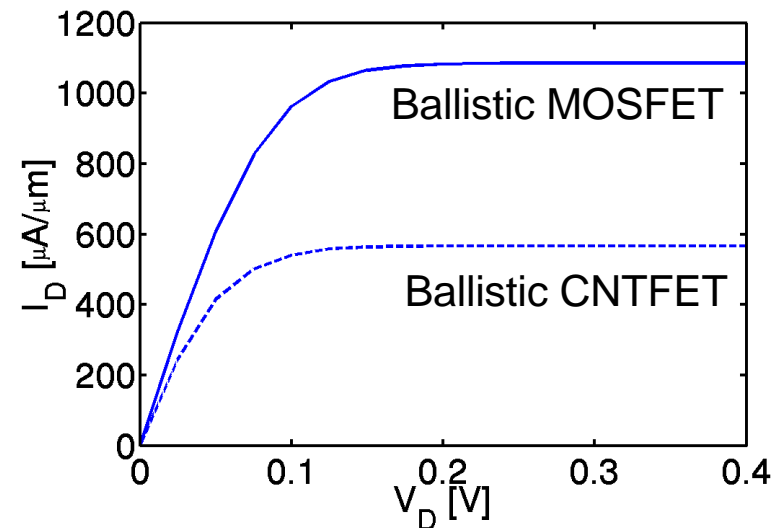

{ coaxial geometry provides  
10X the current per nanotube }

Purdue

# 5. Beyond the Si MOSFET.....

*the CNTFET*

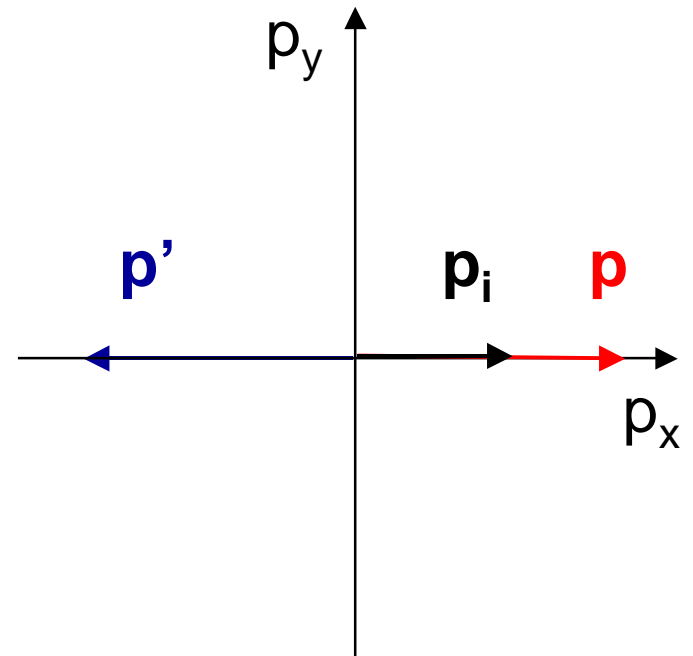
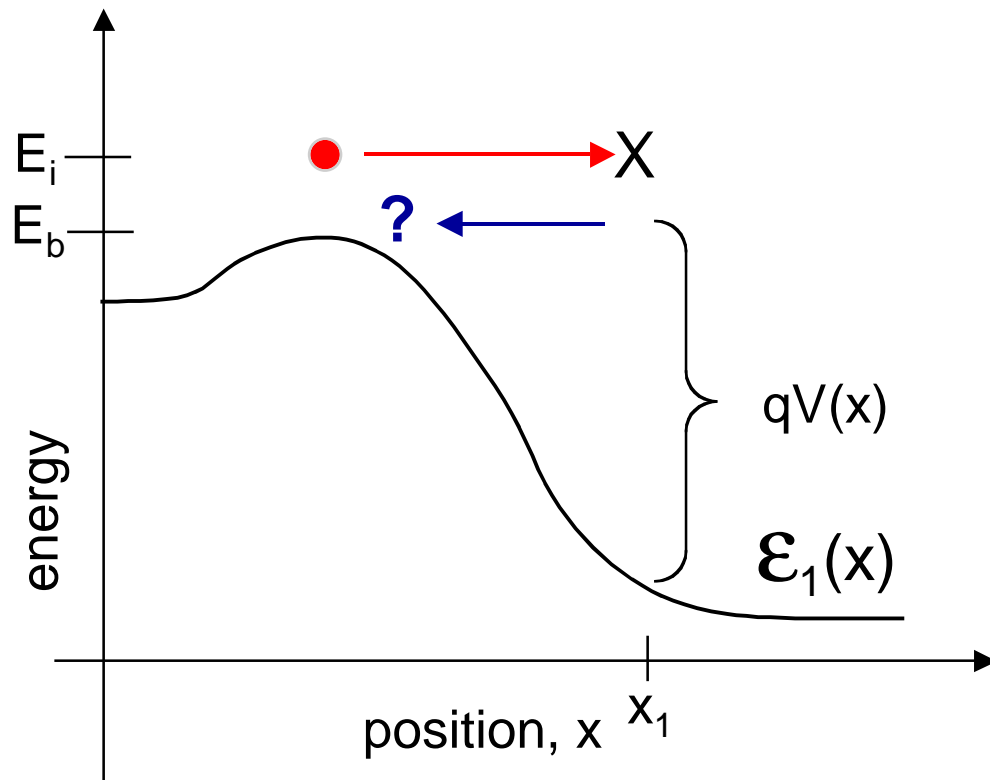

all energy is longitudinal energy:

$$1 \rightarrow L$$

## 6. Summary

---

- Nanoscale transistor physics is simply understood by beginning at the ballistic limit
- Scattering theory provides a simple, physical view of nano-MOSFETs and other transistors
- The NEGF approach is a practical tool for modeling MOSFETs and molecular devices
- The issues for 10nm MOSFETs are the expected ones
- New devices are showing promise